

Diggity Designs XLR8 Set Up Sheet

Date: **10-10-2006** Temp/Air: **82 DEGREES**
 Driver: **TEAM DIGGITY DESIGNS**

Sway Bars: **.078** Front Rear
 ESC: **KO PROPO VFS-1 PRO** Batteries: **3800's**
 Servo: **JR DZ8450** Body: **LOSI LEXUS**

Track/Race Location: **GRAND RAPIDS MICHIGAN**

Comments: **This is a great starting set-up for high to extreme high traction carpet tracks. Use TC4 front steering blocks with the outer ackermann hole . Use TC4 rear bearing blocks (you will need to drill a set screw hole). Mount the arms in reverse and mount the shocks on the inside of the shock tower**

TRACK CONDITIONS

Traction:
 High Bite Med. Bite Low Bite
 Track Difficulty:
 Technical Open Mixed
 Track Surface: Carpet Asphalt

TRANSMISSION SETTINGS

Front Differential <input type="checkbox"/> Loose <input type="checkbox"/> Medium <input checked="" type="checkbox"/> Medium Tight <input type="checkbox"/> Tight	Rear Differential <input type="checkbox"/> Loose <input type="checkbox"/> Medium <input checked="" type="checkbox"/> Medium Tight <input type="checkbox"/> Tight
<input type="checkbox"/> Front One Way	<input type="checkbox"/> Front Solid Diff
Spurgear: 69T 48 PITCH	Pinion: 25-27T
Motor: STOCK	Brush: 767 REEDY

SHOCK SETTINGS

Shocks: Associated Other_____

Associated Front Springs		Associated Rear Springs	
<input type="checkbox"/> #3941 Green 12 lbs	<input type="checkbox"/> #3941 Green 12 lbs	<input type="checkbox"/> #3941 Green 12 lbs	<input type="checkbox"/> #3941 Green 12 lbs
<input type="checkbox"/> #3942 Silver 14.5 lbs	<input type="checkbox"/> #3942 Silver 14.5 lbs	<input type="checkbox"/> #3942 Silver 14.5 lbs	<input type="checkbox"/> #3942 Silver 14.5 lbs
<input type="checkbox"/> #3943 Blue 17 lbs	<input checked="" type="checkbox"/> #3943 Blue 17 lbs	<input type="checkbox"/> #3943 Blue 17 lbs	<input type="checkbox"/> #3943 Blue 17 lbs
<input type="checkbox"/> #3944 Gold 19 lbs	<input type="checkbox"/> #3944 Gold 19 lbs	<input type="checkbox"/> #3944 Gold 19 lbs	<input type="checkbox"/> #3944 Gold 19 lbs
<input type="checkbox"/> #3945 Red 22 lbs	<input type="checkbox"/> #3945 Red 22 lbs	<input type="checkbox"/> #3945 Red 22 lbs	<input type="checkbox"/> #3945 Red 22 lbs
<input type="checkbox"/> #3946 Copper 25 lbs	<input type="checkbox"/> #3946 Copper 25 lbs	<input type="checkbox"/> #3946 Copper 25 lbs	<input type="checkbox"/> #3946 Copper 25 lbs
<input type="checkbox"/> #3947 Purple 30 lbs	<input type="checkbox"/> #3947 Purple 30 lbs	<input type="checkbox"/> #3947 Purple 30 lbs	<input type="checkbox"/> #3947 Purple 30 lbs
<input type="checkbox"/> #3948 Yellow 35 lbs	<input type="checkbox"/> #3948 Yellow 35 lbs	<input type="checkbox"/> #3948 Yellow 35 lbs	<input type="checkbox"/> #3948 Yellow 35 lbs
<input checked="" type="checkbox"/> #3949 White 40 lbs	<input type="checkbox"/> #3949 White 40 lbs	<input type="checkbox"/> #3949 White 40 lbs	<input type="checkbox"/> #3949 White 40 lbs

Springs Other F_____ R_____

Front Oil: 60WT	Rear Oil: 40WT
Front Pistons <input type="checkbox"/> #1 <input type="checkbox"/> #2 <input checked="" type="checkbox"/> #3	Rear Pistons <input type="checkbox"/> #1 <input checked="" type="checkbox"/> #2 <input type="checkbox"/> #3
Inner Shock Limiters Front: <input type="checkbox"/> Yes <input checked="" type="checkbox"/> No Rear: <input type="checkbox"/> Yes <input checked="" type="checkbox"/> No	
Outer Shock Limiters Front: <input type="checkbox"/> Yes <input checked="" type="checkbox"/> No Rear: <input type="checkbox"/> Yes <input checked="" type="checkbox"/> No	

TIRES

Foam Tire Size: 2.24	Rubber Tire:
Brand: JACO	Rim:
Front Compound: PLAID	Front Insert:
Rear Compound: PURPLE	Rear Insert:

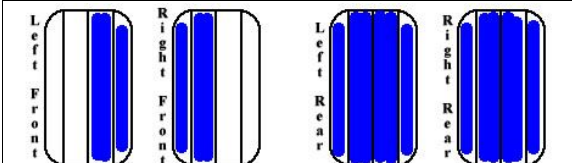

Treated Area (Shade): Additive Type: **PARAGON**

CAR SET UP

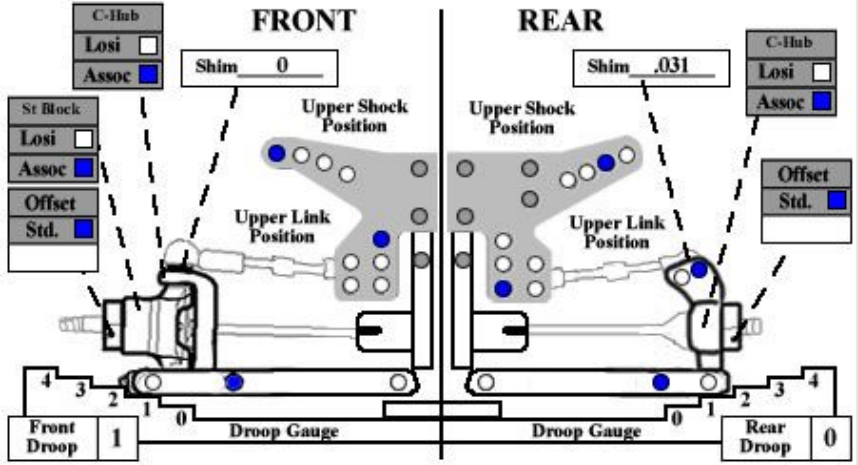
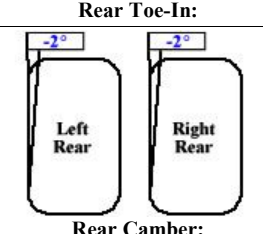
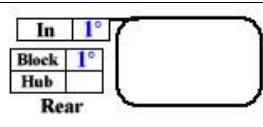
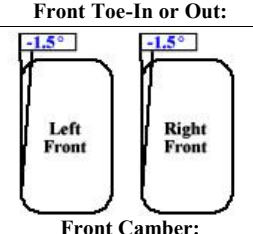
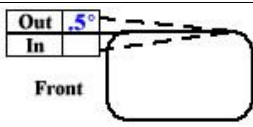
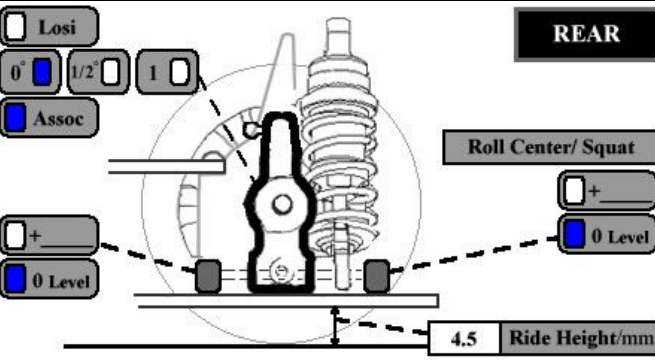
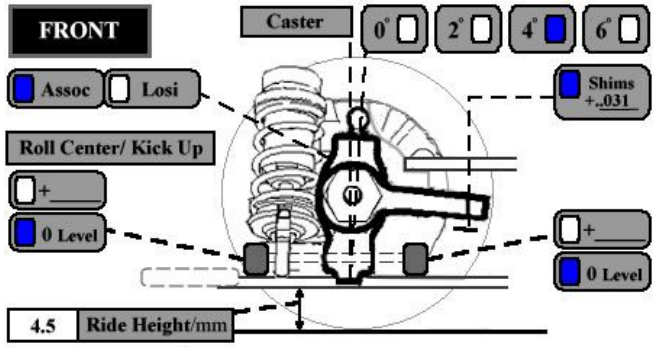

Wheelbase: Long Medium Short