

3D08

Setup Sheet

Date: _____ Temp/Air: _____

Driver: TeamDiggity Designs

Track/Race Location: Local Track Med-High Bite Carpet

Comments: This is a good starting setup for carpet racing

Body Type and Make: Parma Speed 8

Battery Type: 4200's

Motor Type and Wind: Stock or 19T

Gearing: 29 / 96

Speed Control: Tekin FX Pro Current Limiter: None

Receiver: Futaba 2.4Ghz

FRONTEND

Kingpin Lube: Parma Bushing Oil

Springs: .022

Upper Arm Mounts: 0° 5° 10°

Camber: 1.5 °

Caster: 

CRC Orange Yellow and

FRONT RIDE HEIGHT SPACERS: White with NEW Tires

STEERING BLOCK STD INLINE

CAMBER, left 1.5 right 1.5

TOE-IN: _____ ° TOE-OUT: .5 °

SPRINGS: .018 .020 .022 .024 OTHER _____

KINGPIN STD OTHER

LABEL DRAWING FOR SHIM position, qty and thickness:

shim qty, thickness: 5 - (.010)

shim qty, thickness: 0

1 - (.010)

shim qty, thickness: 0

NOTES

Used Lowered Front A-arms

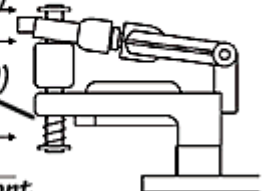

SHOCK

BODY STD OTHER

OIL 25 WT

SPRING CRC Blue

LIMITERS inside _____

outside _____

NOTES

.5-1mm Droop

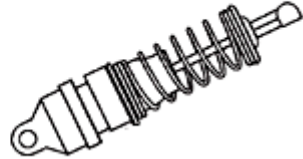

REAREND

Damper Lube: 30,000 Nitro Diff Lube

Ride Height Adjuster: #4-up #1-up #2-up

#3 #2-down #1-down #4-down

Side Springs: CRC Blue

Tire Type (front): CRC Magenta (rear): CRC Pink

Tire Diameter (front): 45.4mm (rear): 47.5mm

Wheel Type (front): Pro-Cuts (rear): Pro-Cuts

Axle Shims: 3 on right - 2 on left

Tire Treatment:

shade is amount of tire treatment



Left Front



Right Front



Left Rear



Right Rear